

# PRODUCT INFORMATION PACKET

Model No: 145TTFR16374  
Catalog No: C231B  
1.5, 1800, TEFC, 145TC, 3/60/575  
Totally Enclosed Fan Cooled (TEFC)



Regal and Marathon are trademarks of Regal Beloit Corporation or one of its affiliated companies.  
©2018 Regal Beloit Corporation, All Rights Reserved. MC017097E





### Nameplate Specifications

Output HP	<b>1.50 Hp</b>	Output KW	<b>1.1 kW</b>
Frequency	<b>60 Hz</b>	Voltage	<b>575 V</b>
Current	<b>1.9 A</b>	Speed	<b>1755 rpm</b>
Service Factor	<b>1.15</b>	Phase	<b>3</b>
Efficiency	<b>86.5 %</b>	Duty	<b>Continuous</b>
Insulation Class	<b>B</b>	Design Code	<b>A</b>
KVA Code	<b>P</b>	Frame	<b>145TC</b>
Enclosure	<b>Totally Enclosed Fan Cooled</b>	Overload Protector	<b>No</b>
Ambient Temperature	<b>40 °C</b>	Drive End Bearing Size	<b>6205</b>
Opp Drive End Bearing Size	<b>6203</b>	UL	<b>Recognized</b>
CSA	<b>Y</b>	CE	<b>Y</b>
IP Code	<b>43</b>		

### Technical Specifications

Electrical Type	<b>Squirrel Cage Induction Run</b>	Starting Method	<b>Across The Line</b>
Poles	<b>4</b>	Rotation	<b>Reversible</b>
Mounting	<b>Round</b>	Motor Orientation	<b>Horizontal</b>
Drive End Bearing	<b>Ball</b>	Opp Drive End Bearing	<b>Ball</b>
Frame Material	<b>Rolled Steel</b>	Shaft Type	<b>T</b>
Overall Length	<b>14.71 in</b>	Shaft Diameter	<b>0.875 in</b>
Shaft Extension	<b>2.12 in</b>	Assembly/Box Mounting	<b>F1 Only</b>
Outline Drawing	<b>OL56100222-001</b>	Connection Diagram	<b>EE7300</b>

This is an uncontrolled document once printed or downloaded and is subject to change without notice. Date Created: 07/02/2018

**THREE PHASE - SINGLE VOLTAGE  
MOTOR - CONDUIT BOX @ 'A'**

**TO REVERSE ROTATION:  
INTERCHANGE ANY TWO  
LINE LEAD CONNECTIONS.**

**TERMINAL BLOCK WHEN SPECIFIED**

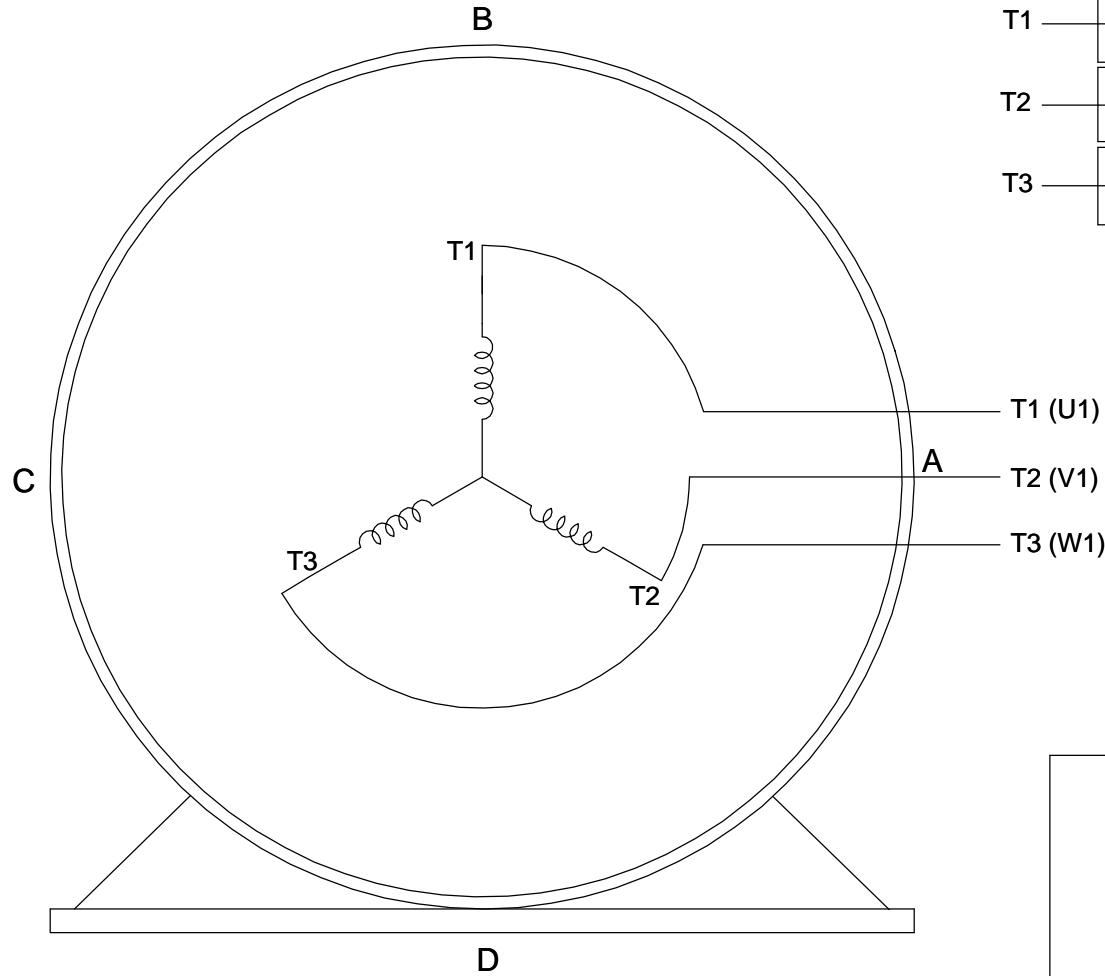
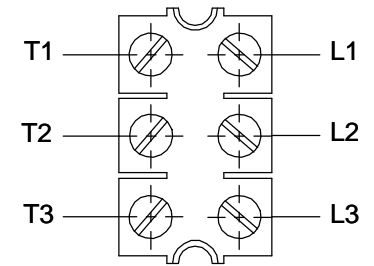

**VIEW OF TERMINAL END**

**IF MOTOR HAS  
6 LEADS**

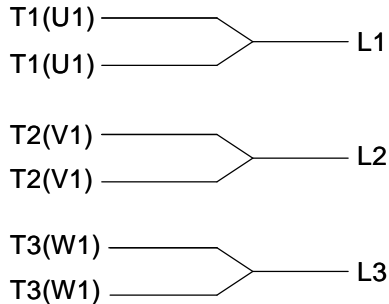

A-9806 DECAL

**OPTIONAL CORD  
CONNECTION**

- L1 \_\_\_\_\_ WHITE \_\_\_\_\_
- L2 \_\_\_\_\_ RED \_\_\_\_\_
- L3 \_\_\_\_\_ BLACK \_\_\_\_\_

DRAWING REVISION AB	REVISION BY JJB	DATE 06-27-2017
ECO ECO-0125361	APPROVED BY TB	DATE 06-27-2017
ECO DESCRIPTION <b>UPDATED TO CURRENT STANDARDS</b>		
<small>COPYRIGHT REGAL BELOIT AMERICA, INC. ALL RIGHTS RESERVED.                  PROPRIETARY AND CONFIDENTIAL INFORMATION - THIS DOCUMENT IS THE PROPERTY OF                  REGAL BELOIT AMERICA, INC. ("OWNER") AND CONTAINS OWNER'S PROPRIETARY                  INFORMATION. ANY PERSON, CORPORATION OR OTHER FIRM RECEIVING IT IS DEEMED,                  BY RECEIVING IT, TO AGREE THAT IT, AND/OR ANY PART OF IT, SHALL NOT BE DISCLOSED                  TO ANY PERSON, CORPORATION OR OTHER ENTITY, DUPLICATED, AND/OR USED, EXCEPT                  AS EXPRESSLY APPROVED IN WRITING IN ADVANCE BY OWNER. THIS DOCUMENT SHALL                  BE RETURNED TO OWNER UPON REQUEST. IT MAY BE SUBJECT TO CERTAIN                  RESTRICTIONS UNDER APPLICABLE EXPORT CONTROL LAWS AND REGULATIONS.</small>		

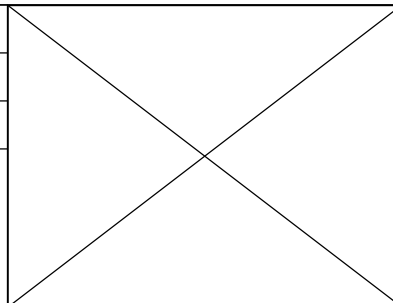

DRAWN BY DA
DATE 03-26-1993
APPROVED BY TB
DATE 03-26-1993
REFERENCE
THIRD ANGLE PROJECTION

 <b>Regal Beloit America, Inc.</b>		
		DESCRIPTION <b>CONNECTION DIAGRAM</b> EXTERNAL - SINGLE VOLTAGE - 3Ø MOTOR
MATERIAL	PROCESS/FINISH	
SIZE <b>A</b>	DRAWING NUMBER <b>EE7300</b>	SHEET 1 OF 1



Data Sheet

148TFR16374



Submission  
Data @ 575 V

Date: 6/19/2017

Customer:   
Attention:   
Submitted by: FAREEDA DUDEKULA

Motor Load Data

Load	0%	25%	50%	75%	100%	115%	125%	LR
Current (Amps)	1.20	1.24	1.40	1.60	1.84	2.00	2.12	19.2
Torque (ft-lb)	0.00	1.10	2.20	3.5	4.5	5.2	5.7	21.2
RPM	1800	1790	1780	1765	1755	1750	1745	0
Efficiency (%)		74.0	82.5	85.5	86.5	86.5	85.5	
P.F. (%)	7.5	30.5	49.0	62.5	71.0	75.0	77.0	69.5

Motor Speed Data

	LR	Pull-Up	BD	Rated	Idle
Speed (rpm)	0	130	1190	1755	1800
Current (Amps)	19.2	18.6	12.8	1.84	1.20
Torque (ft-lb)	21.2	20.2	26.0	4.5	0.00

Information Block

HP	1.5			
Sync. RPM	1800			
Frame	145			
Enclosure	TEFC			
Construction	TFR			
Voltage	575 V			
Frequency	60 HZ			
Design	A			
LR Code letter	P			
Service Factor	1.15			
Temp Rise @ FL	35 °C			
Duty	CONT			
Ambient	40 °C			
Elevation	1,000 feet			
Rotor/Shaft wkt	0.14 Lb-Fe			
Rel Wdg	Z14256 FR			
Sound Pressure @ 1M	62 dbA			
VFD Rating	NONE			
Outline Dwg	TBD			
Conn. Diag	EE7300			
Additional Specifications:				
0				
EQUIV CKT (OHMS/ PHASE)				
R1	R2	X1	X2	Xm
7.5600	5.9060	11.1330	11.1920	296.2580

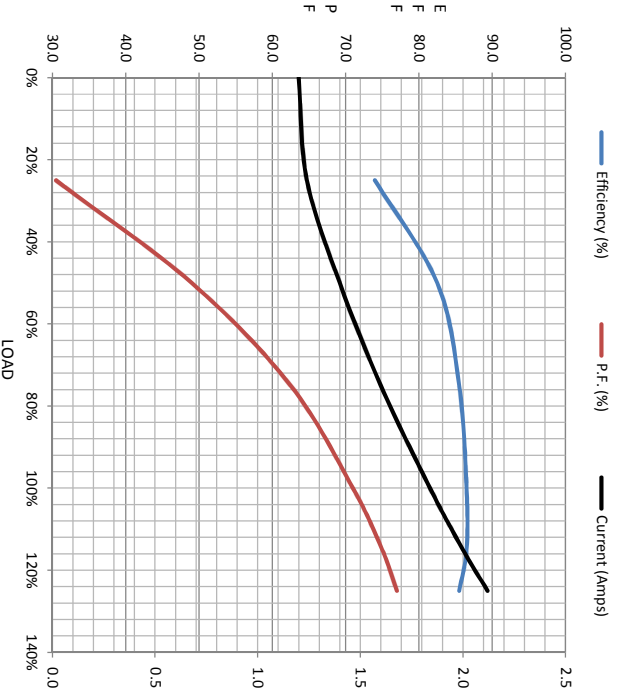

Speed - Torque Curve

